

## Rotary switching element

forwards and backwards (in cycles)

With our rotary switching element many problems can be solved inexpensively in mechanical engineering and special machine construction.

Through the possibility of forward and backward clock cycles, the cycle times in comparison to conventional rotary elements are reduced.

### Application:

- for separation of parts
- for manual and automatic assembly work
- to maintain the position of the tool and tool change on automatic machines
- as a stop change system (turret stop)
- and much more

### Equipment:

The rotary switching element is completely ready for connection. Additionally equipped with a control block, it is a compact ready-to-use component.

To operate, all you need is a pneumatic connection with max. 8 bar and a 3/2 control valve and a second control valve to clock the forward and backward cycles.

All pickups and positions of the component can be queried by sensors for control.

The compact design and the possibility of forward and reverse clocking, we offer a rotary switching element with great versatility.

### Design:

The stop is designed for maintenance-free operation. It is recommended to use only oiled, clean and dry air. All aluminium parts are anodized; the steel parts are burnished and the wearable parts hardened and ground

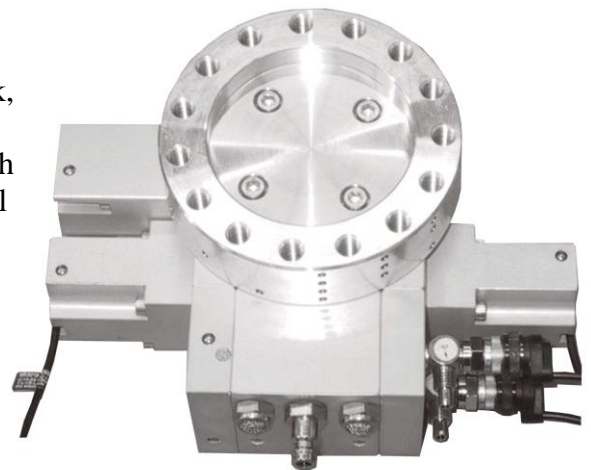
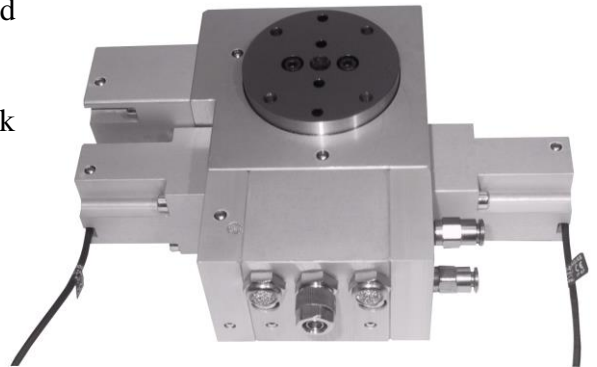

# Rotary switching element

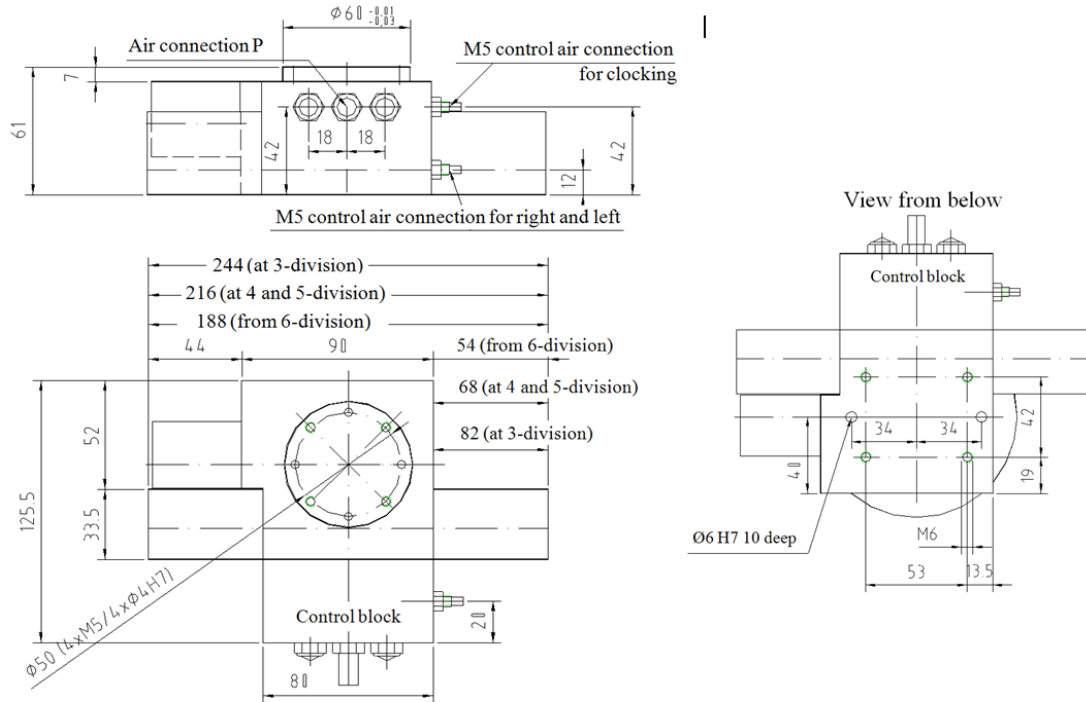

# Rotary switching element as turret stop

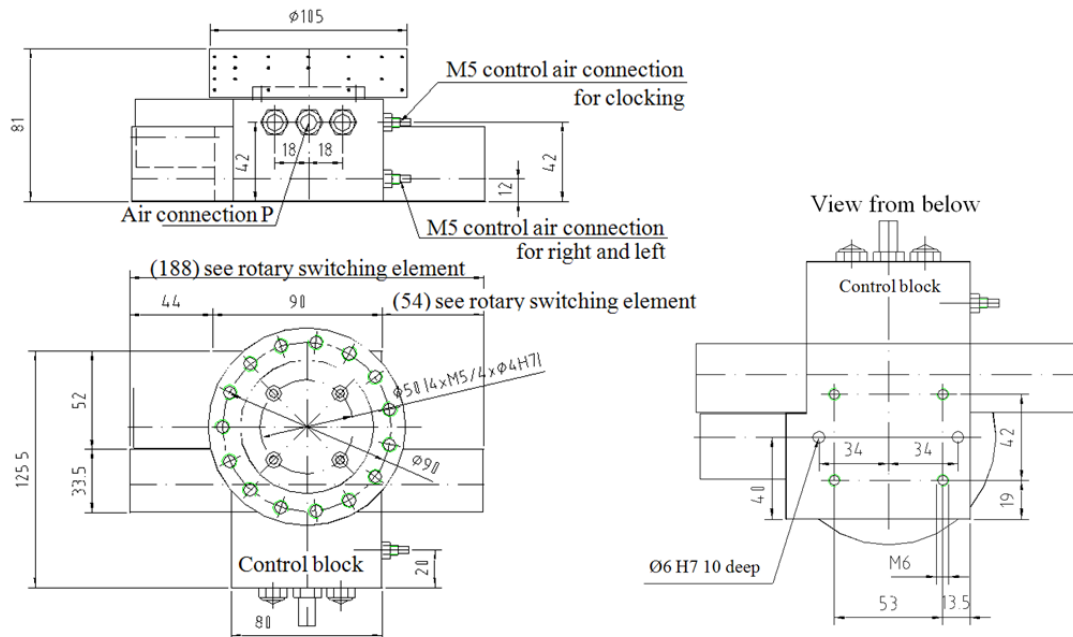

## Technical Data

<b>Indexing accuracy:</b>	approx. 60 sec.
<b>Stop points:</b>	4 to 15 pieces and divisions
<b>Mass shift:</b>	approx. 2500 g
<b>Axial load within Ø 90mm:</b>	approx. 800 N at 3 - 4 m per min. undamped (approx. 8600 N at damped drives)
<b>Weight:</b>	approx. 2800 g
<b>Air consumption:</b>	at 6 bar approx. 0.026 NL per cycle at 15 fold
<b>Cycle time:</b>	approx. 0.12 sec. at 15 fold
<b>Rated torque:</b>	approx. 7.8 Nm (in theory)
<b>Service life:</b>	over 10,000,000 cycles